

# BALL NON-RETURN VALVES – WITH FLANGE



## BALL CHECK VALVES

- Used for one-way flow of sewage water,
- applicable to the pressure sewer or pumping stations,
- dimension with flange – DN50 to DN300,
- connection with flange DIN2533 PN19 and AS4087,
- maximum working pressure 16 Bar,
- operating temperature 10 ÷ 80 °C,
- seating according to category A standard ISO 5208,
- minimum back-pressure for tightness: 0,3 to 0,5 Bar,
- dimensions of flange type according to EN-558-1 series 48 (DIN3202 F6),
- un-reduced full flow,
- self-cleaning rubbered iron ball,
- stainless steel screws SS316,
- low pressure drop,
- silent operation,
- removable bonnet for cleaning or changing the ball,
- horizontal and vertical installation in the pipeline.

Type	Connection (mm)	L	Dimensions (mm)					H
			D	D1	D2	N-D	B	
DN50	50	200	165	125	102	4-19	19	100
DN65	65	240	185	145	122	4-19	19	125
DN80	80	260	200	160	138	8-19	19	136
DN100	100	300	220	180	158	8-19	19	185
DN125	125	350	250	210	188	8-19	19	196
DN150	150	400	285	240	212	8-23	19	265
DN200	200	500	340	295	268	12-23	20	340

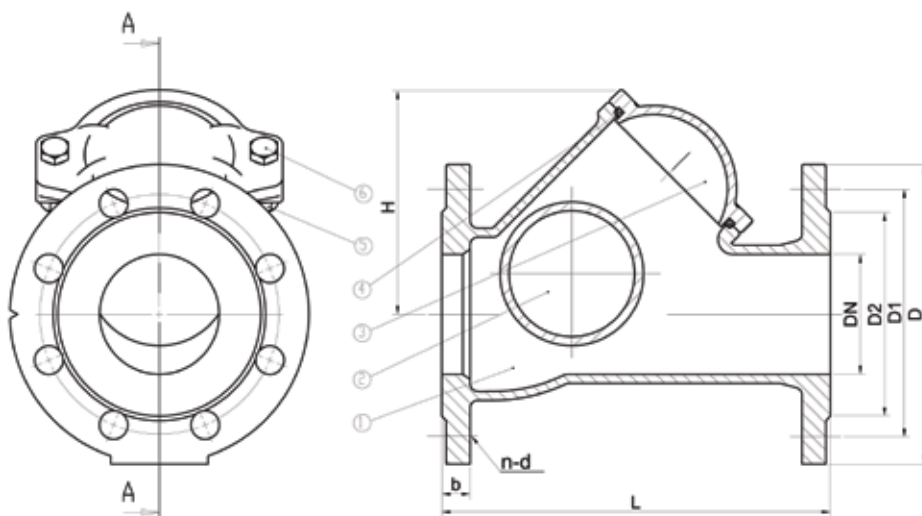

Type	Name	Material
1	Body	GG 40 s FEB coated
2	Ball	Steel + EPDM / NBR
3	Bonnet	GG40
4	Bonnet seal	NBR or EPDM
5	Screw	Stainless steel
6	Nut	Stainless steel