

# GD

## Grinder Pump

# GDH

## High Head Grinder Pump

Liquid temperature: 0°C to 40°C / +32°F to +104 °F  
HP range: 1.5 HP to 3 HP /  
1.1 kW to 2.2 kW  
pH: 6 to 8  
Rated Speed: 2900/3450rpm  
Protection class: IP68  
Maximum depth: 8M

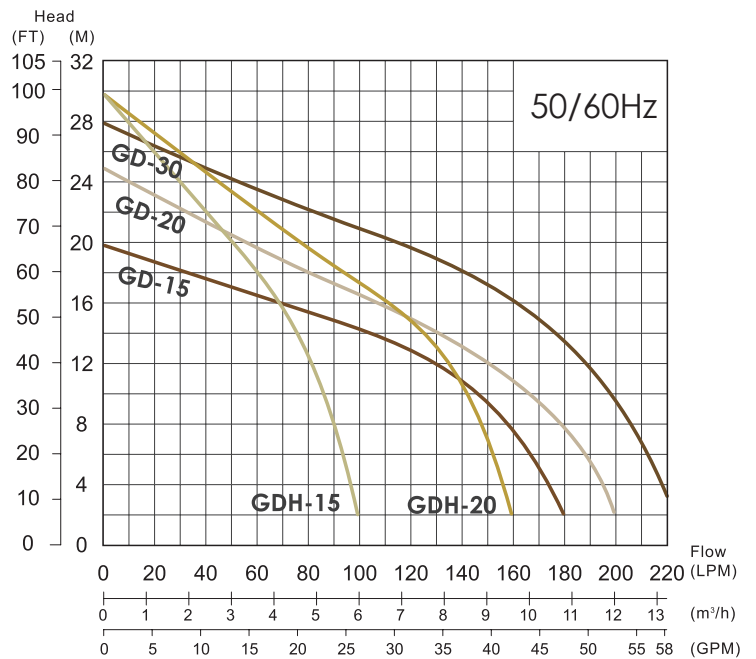
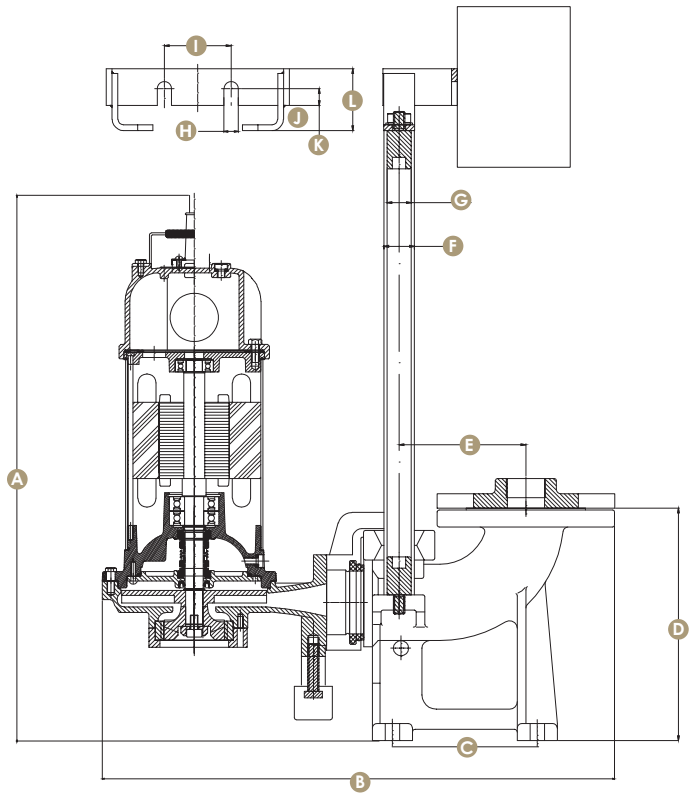

### Dimension

Unit:mm

Model	A	B	C	D	E	F	G	H	I	J	K	L
GD-15	572	538	152	275	133	32	25.4	125	70	15	17.5	65
GD-20	597	538	152	275	133	32	25.4	125	70	15	17.5	65
GD-30	596	543	152	275	133	32	25.4	125	70	15	17.5	65
GDH-15	572	538	152	275	133	32	25.4	125	70	15	17.5	65
GDH-20	574	542	152	275	133	32	25.4	125	70	15	17.5	65

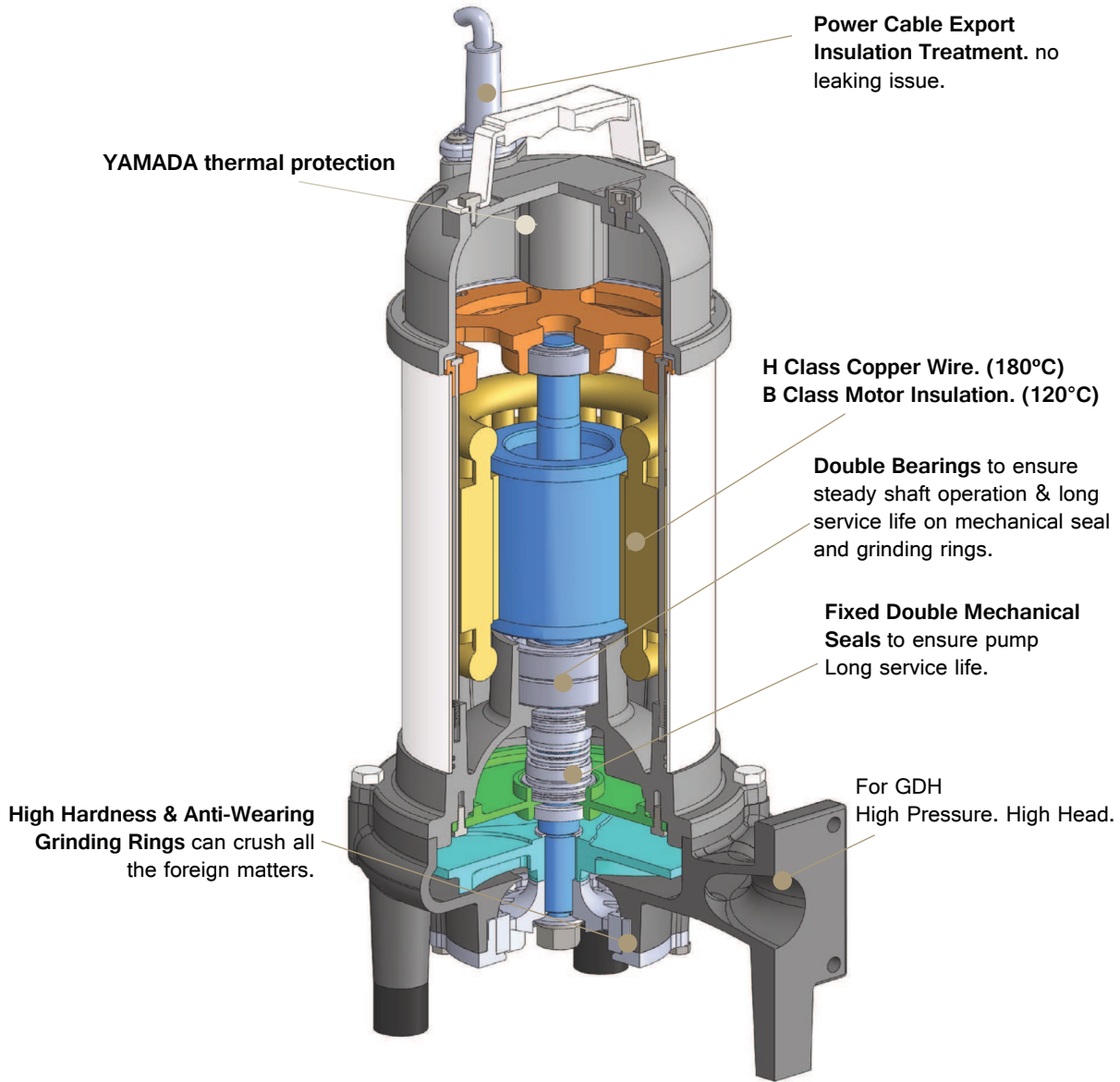

Cutter Impeller Design

2" outlet

1 1/4" outlet

**Specifications**

Model No.	Output		Outlet		Max	LPM Flow @ Head					Max Head(M)	Dimension L x W x H(mm)	Weight Kg
	HP	kW	mm	inch		5M	10M	15M	20M	25M			
GD-15	1.5	1.1	32	1-1/4"	180	170	150	80	-	-	20	236 x 191 x 540	30
GD-20	2	1.5	32	1-1/4"	200	190	155	110	45	-	25	236 x 191 x 560	32
GD-30	3	2.2	32	1-1/4"	230	210	195	160	110	40	28	236 x 191 x 560	35
GDH-15	1.5	1.1	32	1-1/4"	100	95	85	70	40	20	30	240 x 174 x 540	30
GDH-20	2	1.5	32	1-1/4"	160	155	145	120	75	35	30	240 x 174 x 560	32