

GS

High Head Grinder Pump

4 - Pole Motor

Liquid temperature: 0°C to 40°C / +32°F to +104 °F
HP range: 1.5 HP / 1.1 kW
pH: 6 to 8
Rated Speed: 1450/1750rpm
Protection class: IP68
Maximum depth: 8M

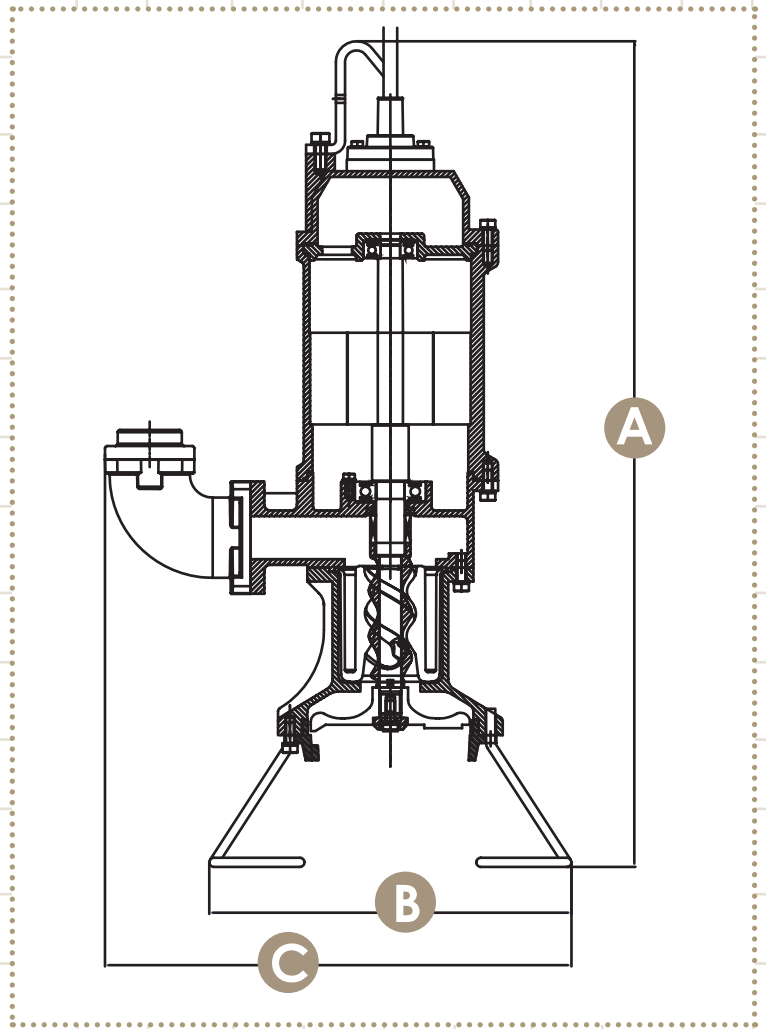

Dimension	Unit:mm		
	Model	A	B
GS-15	720	316	407

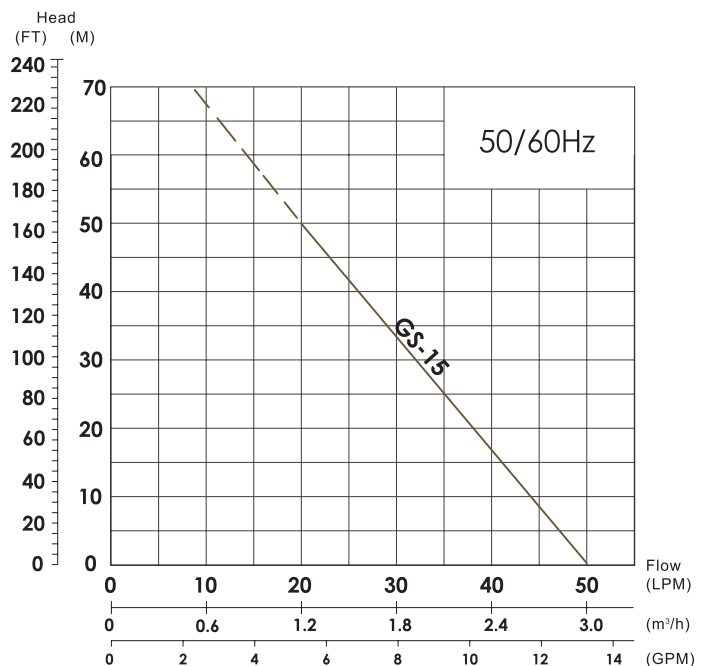

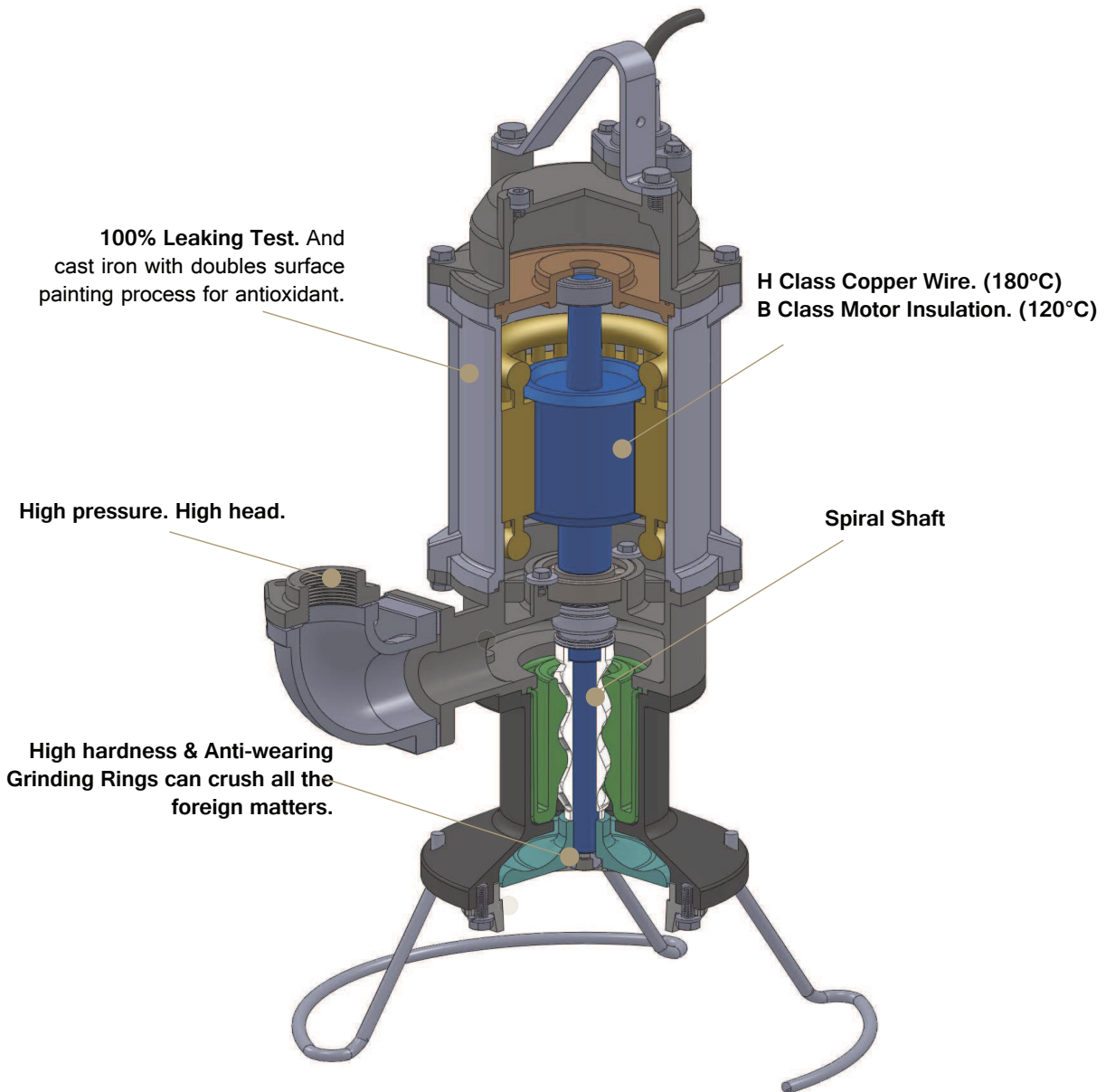

2" outlet



1 1/4" outlet



Cutter Imepller Design

Specifications

Model No.	Output		Outlet		Max Flow(LPM)	LPM Flow @ Head					Dimension L x W x H(mm)	Weight Kg
	HP	kW	mm	inch		10M	20M	30M	40M	50M		
GS-15	1.5	1.1	32	1-1/4	50	45	37	32	25	20	407x316x720	40